



**3DEXPERIENCE®**

**CSD&mAsia**

February 26, 2016

# DS Industry 30 years evolution



**3D**  
Design

V3

**3D DMU**  
Digital Mock-up

V4

**3D PLM**  
Product Lifecycle  
Management

V5

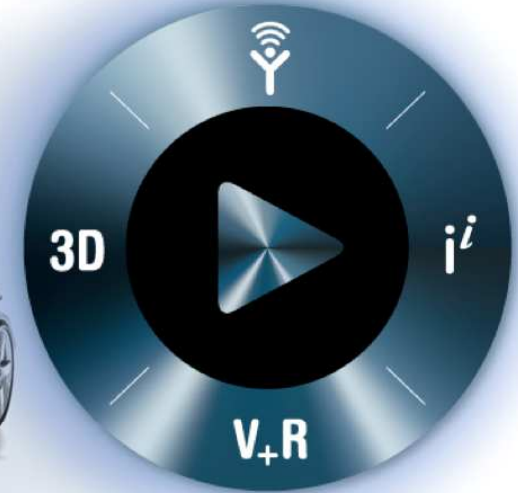

**3DEXPERIENCE**

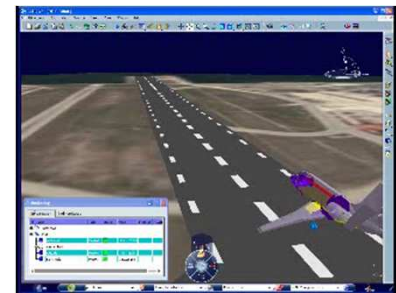

V6

# The World is Changing

## Smart Products require Multi-Discipline Collaboration



Smart Appliances



Smart Cars



Smart Trains



Smart Clothes



Smart Shopping



Smart Phones

# Embedded Systems – Growing Quantity & Complexity

## Space Shuttle / Aircraft



### Space Shuttle (1982)

- 5 CPUs on Board
- 700 Kb of Software
- 0.5 Mil. LOC

### Boeing 777 (1995)

- Approximately 3 Million LOC

## Luxury Vehicle



### 2015 Model Year Luxury Automobiles

- 50-120 CPUs
- 2GB of Software
- 100 Million LOC
- 5,000 Software Parameters
- 30,000 Functional Requirements
- 600,000 Pages of E/E Specifications

Improved Embedded Software & Electronic Systems development capabilities are needed to simplify the delivery of high quality and robust embedded systems

# Notion of complexity: examples

## Vehicle Project :

1500 m.y

1 Billion of Euros

3 years of development

30 to 50 **different disciplines**



## Aircraft Project :

10000 m.y

10 Billions of Euros

5 years of development

30 à 50 **different disciplines on different countries**

## Aerospace Project :

6 Billions of Euros

10 years of development

50 different disciplines on different countries



# Challenges

## ► Function Innovations

- ▷ HMI, Internet applications, Active ADAS (including Driverless)
- ▷ Inboard, Offboard communications
- ▷ Energy efficient management
- ▷ Safety
- ▷ Updates Over the Air

## • Process Challenges

- Decoupled Architectures Requirements / Functions / HW to provide flexibility
- Platform approach
- **Diversity Coverage**

## • Technology Challenges

- **Big Data**, Multi-Core, Multi-OS
- Bus technologies
- New Screens, Telematics multi technologies

## • Integration Challenges

- Vehicle Functional Specification seamless integration
- SW Design
- Electrical Harness

# Best in Class Industry Initiatives

## 2 Transformation Paradigms supporting the transformation

- **Fonctionnal Architecture** Design driving the development
- **Modularity** for SW & HW to control and protect IP

## Key Process initiatives

- Drive Systematic **Re-use**: platform approach
- Frontloading of already validated **Architecture Modules** at Functional level
- Single Source of truth **integrating** Functional/SW/HW Architects and suppliers for speed and quality of development



## ▶ Business Benefits

- ▷ Flexible HW upgrades
- ▷ SW shared across product lines
- ▷ Online SW upgrade on used cars
- ▷ Costs down (Re-use)
- ▷ Quality (Re-use)
- ▷ Timecycle (Re-use)

# Integration is the key

“Engineering has taken us to a stage where we are beginning to rationalize and reintegrate things that we have spent many decades separating and ‘optimizing.’ Now, the potential of science can enable us to take the next step in this journey.”

*Lester Faleiro, Liebherr-Aerospace Lindenberg GmbH  
Project Manager, Power Optimized Aircraft*

**POWER LEVEL INCREASE WITH TIME  
- SPECIFIC EXAMPLES**

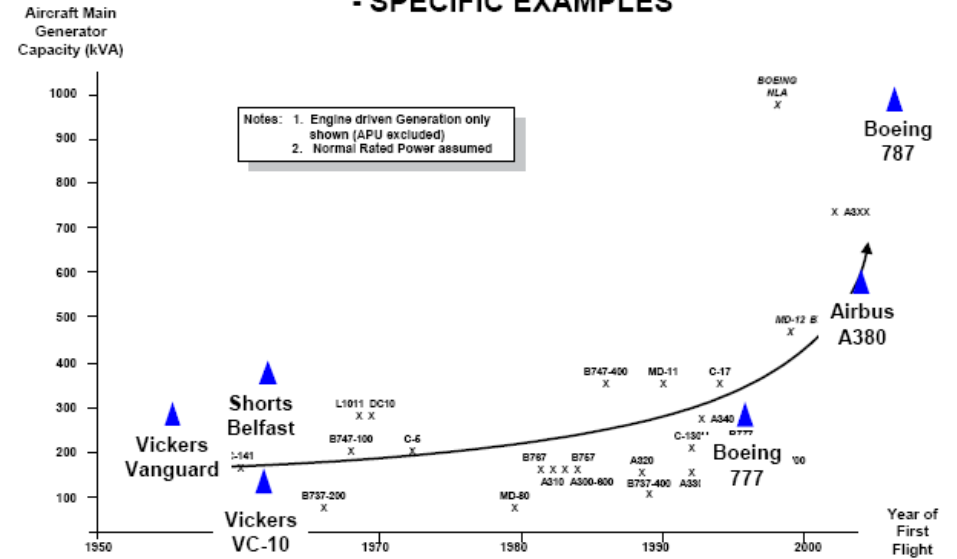

# Collaboration between disciplines



## Disciplines Models

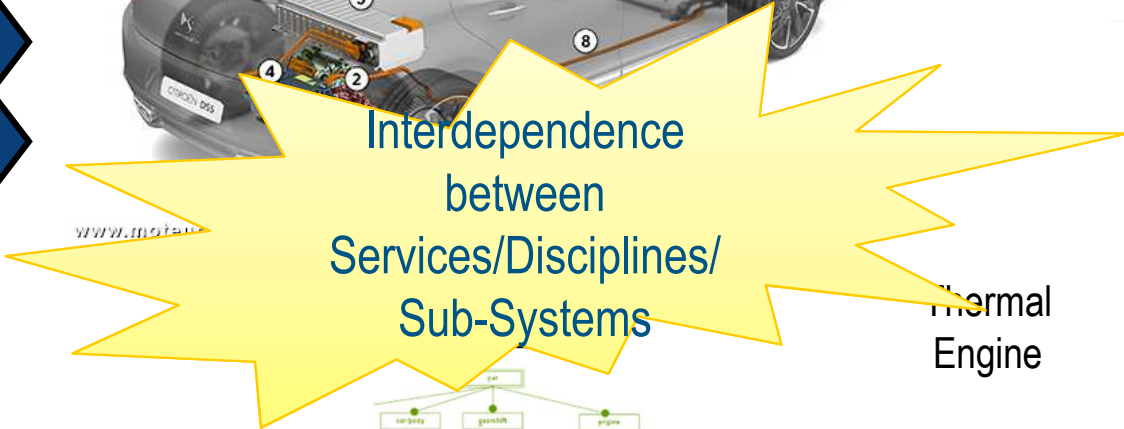
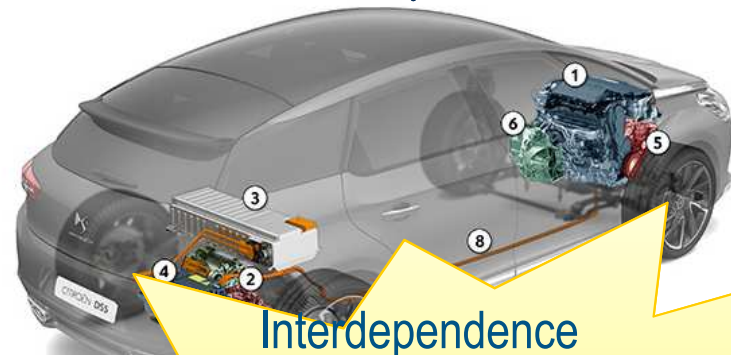
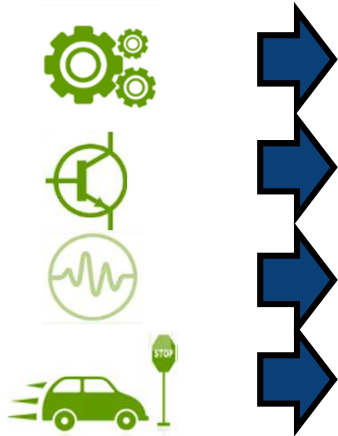

## Architecture : Inter-disciplines trade-offs Models

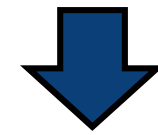

Needs to suppliers

## Sub-Systems

Thermal Engine      Battery      Electrical Engine



# Systems Engineering

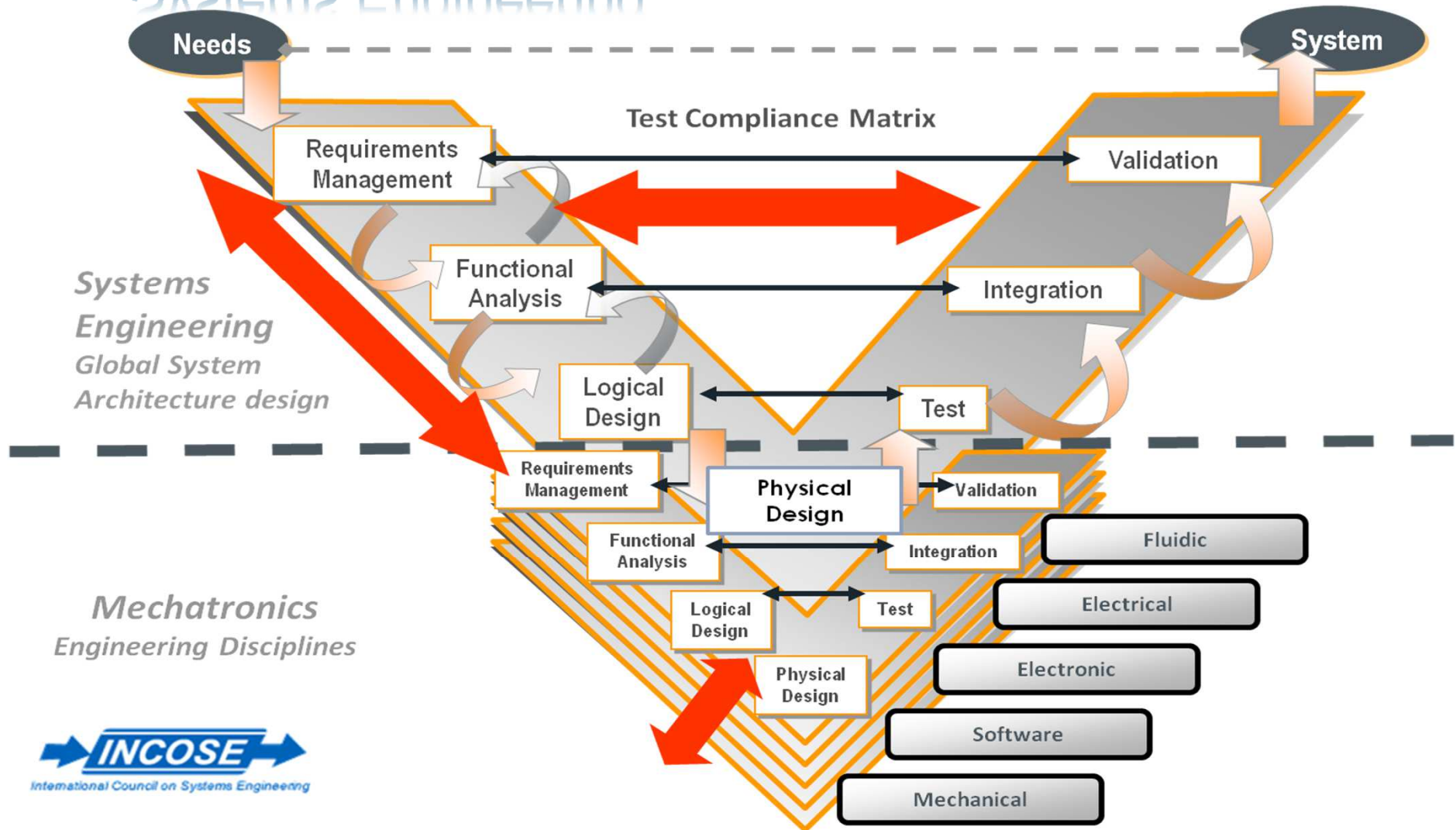

# 3DEXPERIENCE Platform to Master Product Definition

3DS.COM © Dassault Systèmes | Confidential Information | 3/16/2016 | ref.: 3DS\_Document\_2014

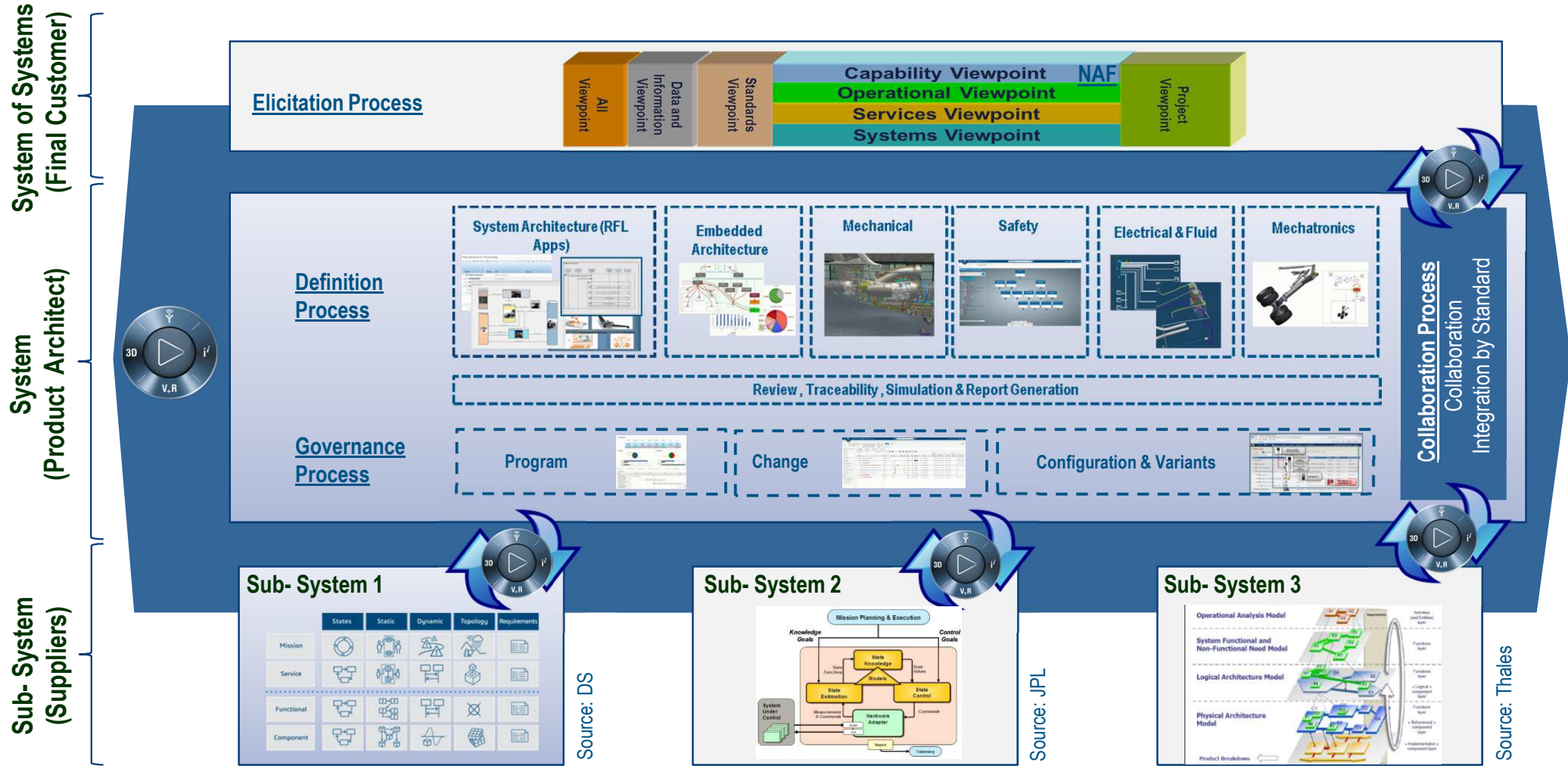

# 3DEXPERIENCE Platform to Master Product Definition - Values

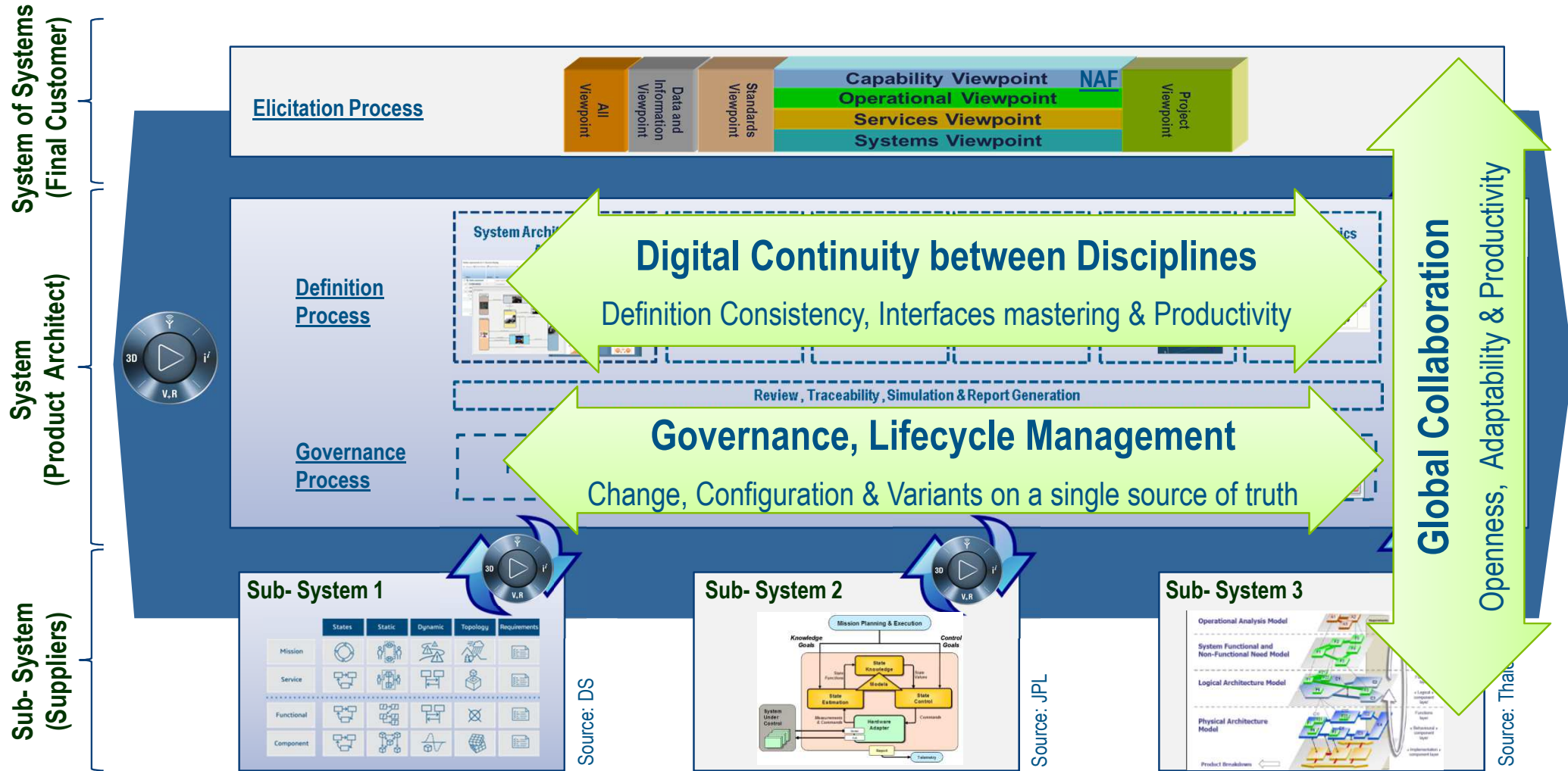

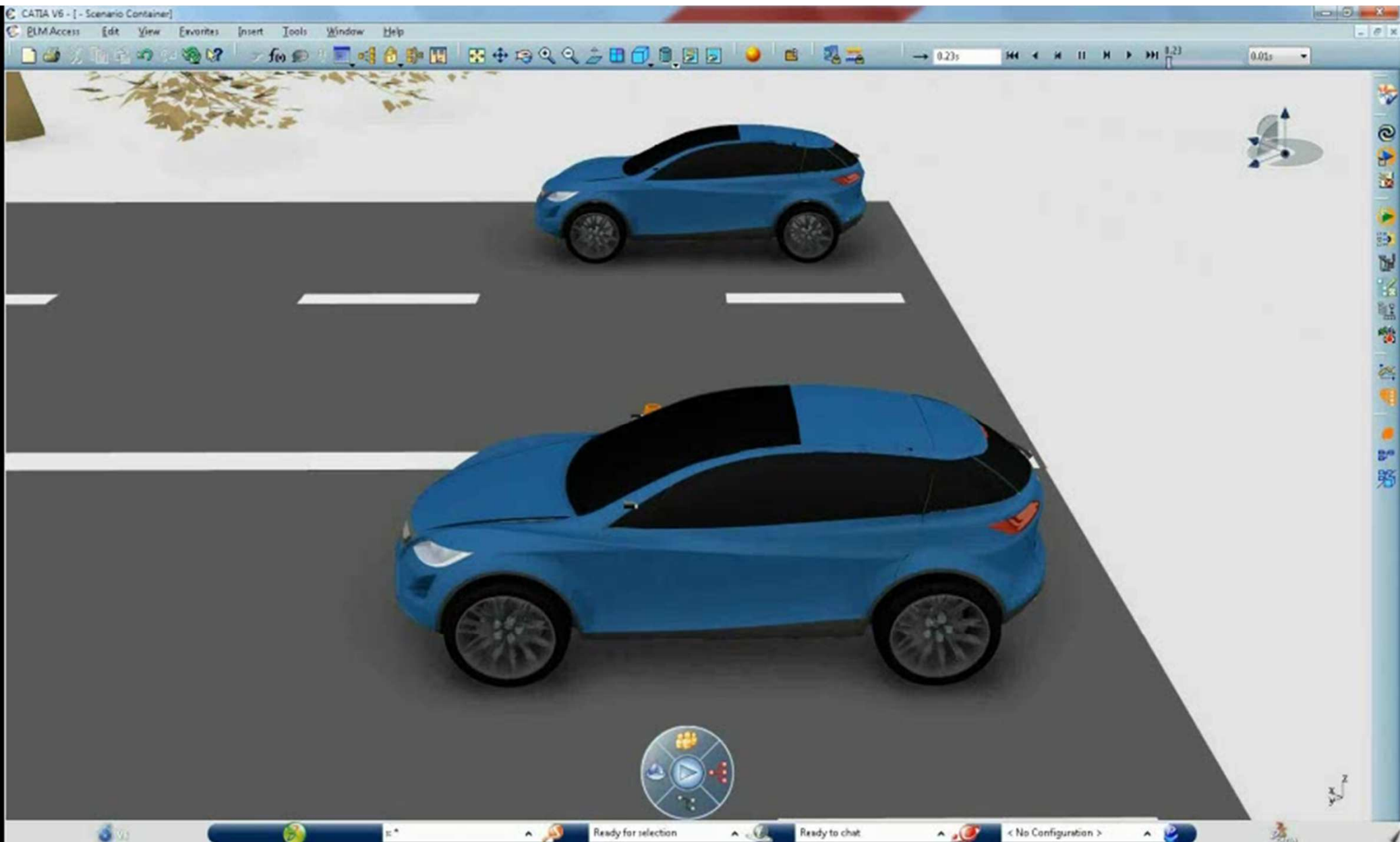

# System Engineering in PLM

- A unified system definition in the context of life cycle management
- **Model Based Systems Engineering (MBSE)**  
System reasoning adaptable to customer process from different point of views: Operational, Functional, Components
- **Multi-disciplines integration**  
Digital Continuum across disciplines (From Systems Engineering to Electrical, Fluidic , Mechanical)
- **Openness**  
Management of heterogeneous models in configuration, in a single environment, in the context of a Product Structure

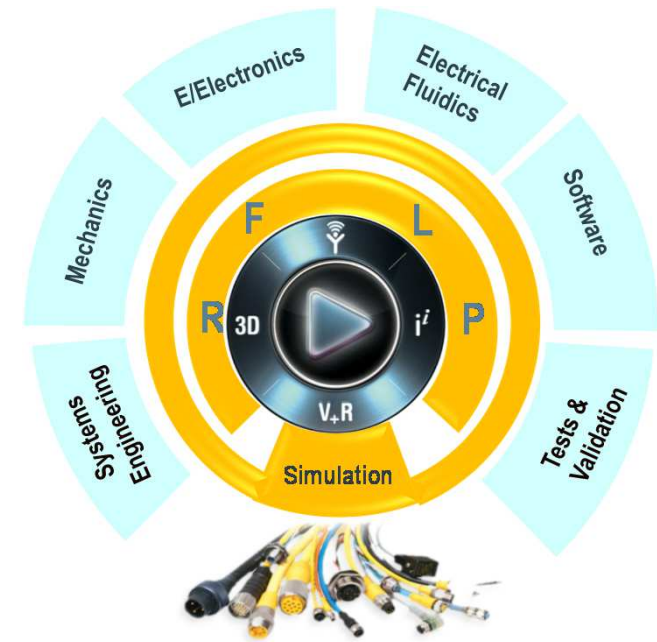

# R-F-L-P Framework

New paradigms, new technologies

## Requirements



Description

*What it should satisfy*

## Functional Architecture

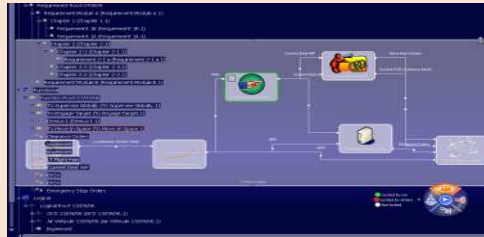

Functions & Services

*What it should do*

## Logical Architecture

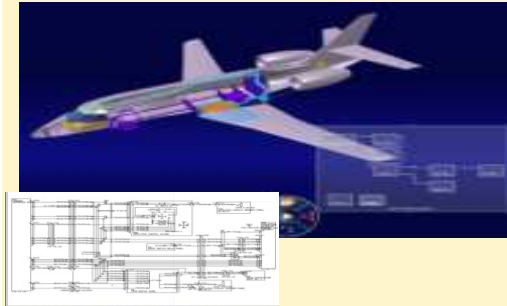

Systems Architecture

*How it will be achieved*

## Physical Model



Implementation

*How it will be realized*

## Single Platform

### Requirements

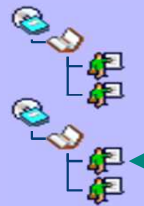

### Functions decomposition

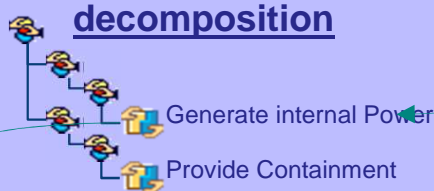

### Logical decomposition



### Physical decomposition

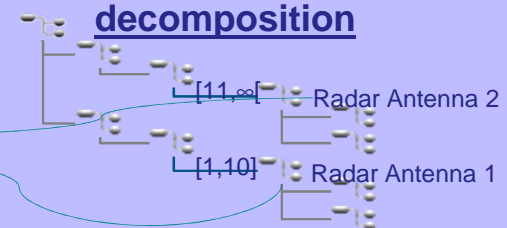



# Embedded Electronics Bottle Neck

THINK ACT  
CONSOLIDATION IN VEHICLE ELECTRONIC ARCHITECTURES

## AUTOMOTIVE TRENDS (\*)

IMPACT ON ECU PROLIFERATION AND INCREASED COMPLEXITY

More, bigger, higher quality screens e.g., reconfigurable clusters	⚡	⚙️
Improved HMI e.g., touchpads, gesture control	⚡	⚙️
Greater content requirements e.g., IVIs running multiple OSs	⚡	⚙️
Increased inter-ECU communication e.g., navigation information simultaneously displayed on the IVI, cluster and HUD	⚡	🌐
Increasing ADAS cockpit penetration e.g., lane departure warning	⚡	🌐
New Active ADAS features e.g., active lane departure avoidance	⚡	🌐
New demands on telematics units e.g., WiFi, OTA updates	⚡	🌐
Higher emissions and fuel economy standards e.g., manage additional sensory input and provide system control	⚡	🌐

**LESS ECUs, PROCESSING POWER REQUIRED, AND E/E ARCHITECTURE COMPLEXITY**

⚡ More ECUs

**MORE ECUs, PROCESSING POWER REQUIRED, AND E/E ARCHITECTURE COMPLEXITY**

⚡ Increased processing power requirements

🌐 Increased E/E architecture complexity

Source: Roland Berger

ROLAND BERGER STRATEGY CONSULTANTS

5

## ECU Patchwork Explosion

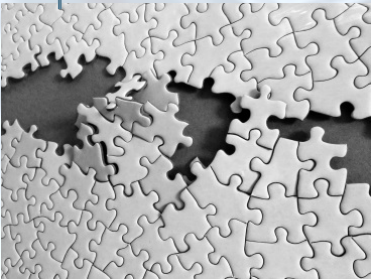

## Architecture Complexity

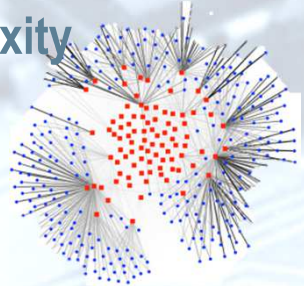

## Buses Saturation

**Low Quality !**

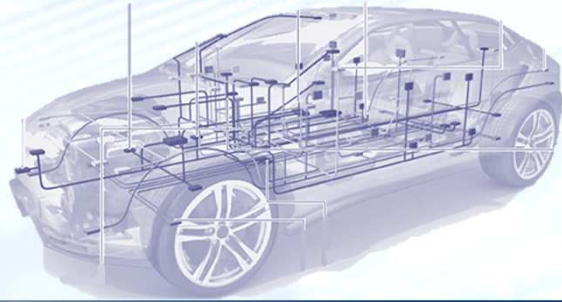

# Vehicle E/E Architecture | Complexity

- **E/E Architecture & its development process to be rethought :**

- Manage COMPLEXITY of new features
- RE-USE components, handle **VARIANTS**
- OPTIMIZE numbers of ECUs, electrical components and wires.

- **E/E platform, an answer:**

- Unique architecture addressing all the variants, one or several vehicle projects.
- Few E/E platforms by OEM (up to 5 at a given time)

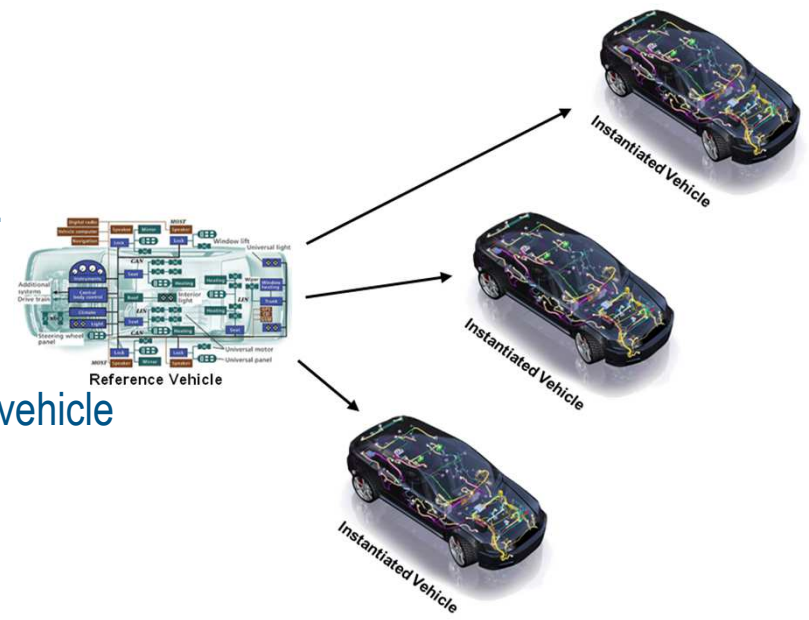

# Generic / Project Approach

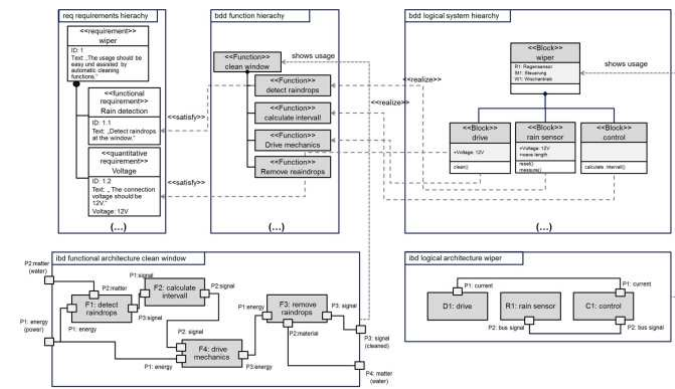
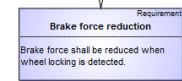
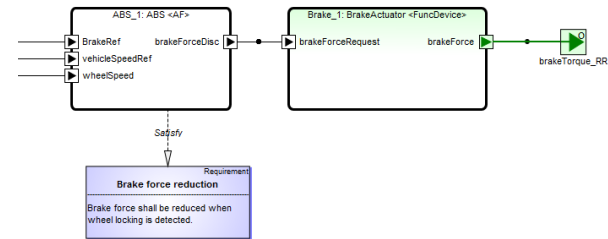
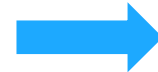

Customer & Regulatory Feature List (generic)



Functional Architectures (generic)

# Generic / Project Approach

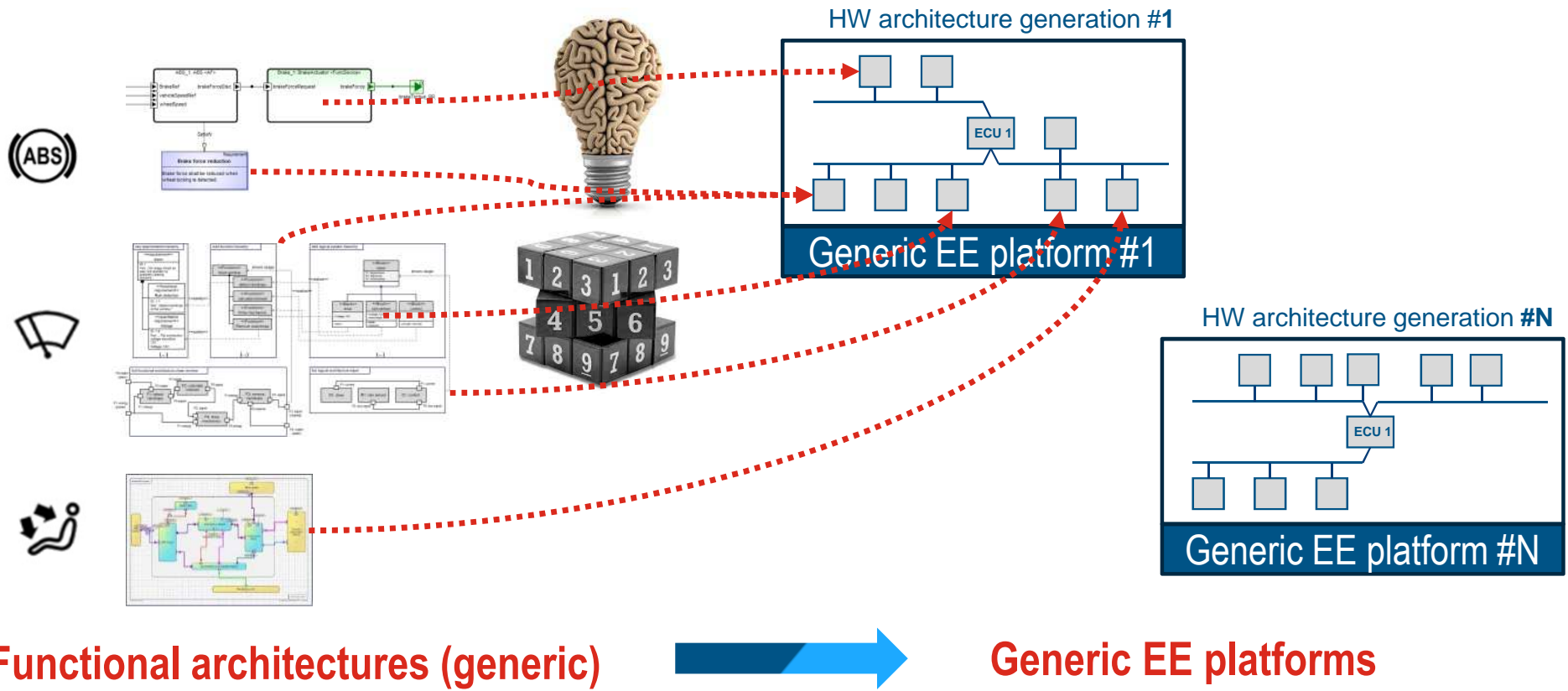

# Generic / Project Approach

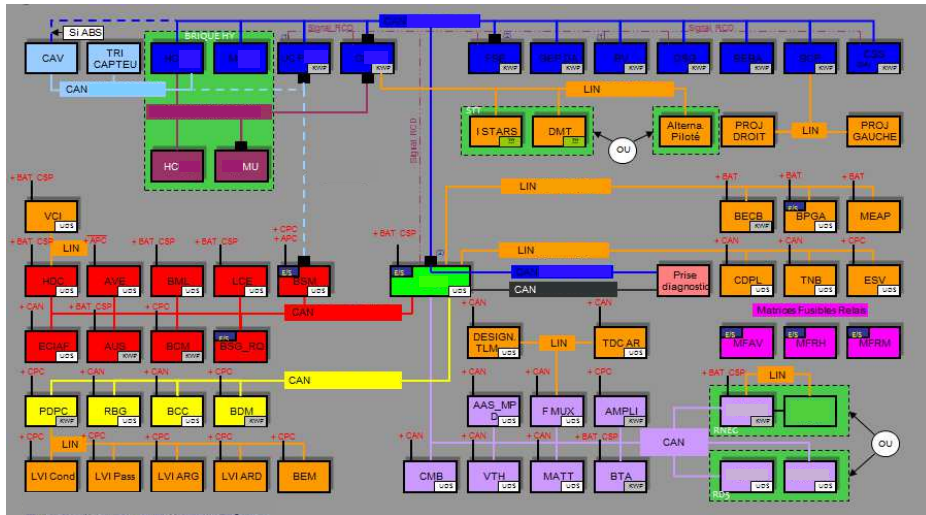

Generic EE platforms

Variance & filtering mechanisms

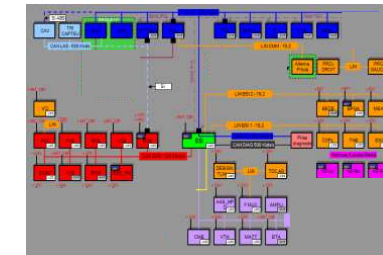
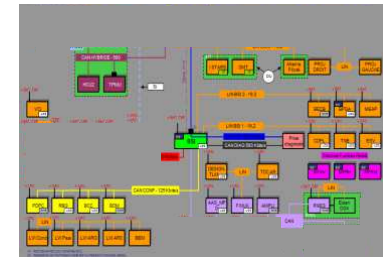
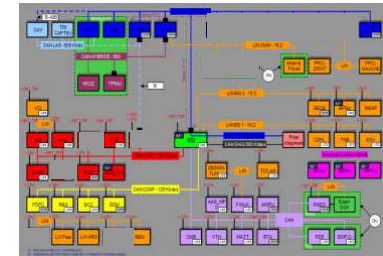

Project:  
Vehicle EE architecture

# Generic / Project Approach

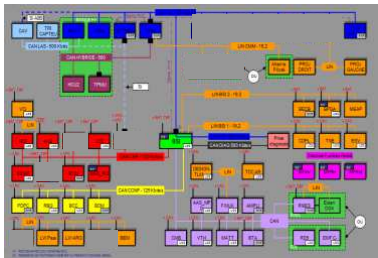

ECU specifications (functions/SW, requirements, I/F)



Applicative communication matrix



BOM E/E (link with Mechanical design)

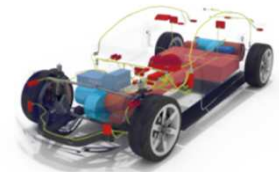

E/E architecture Interfaces list (input to electrical)



# E/E architecture disciplines vs EEA features

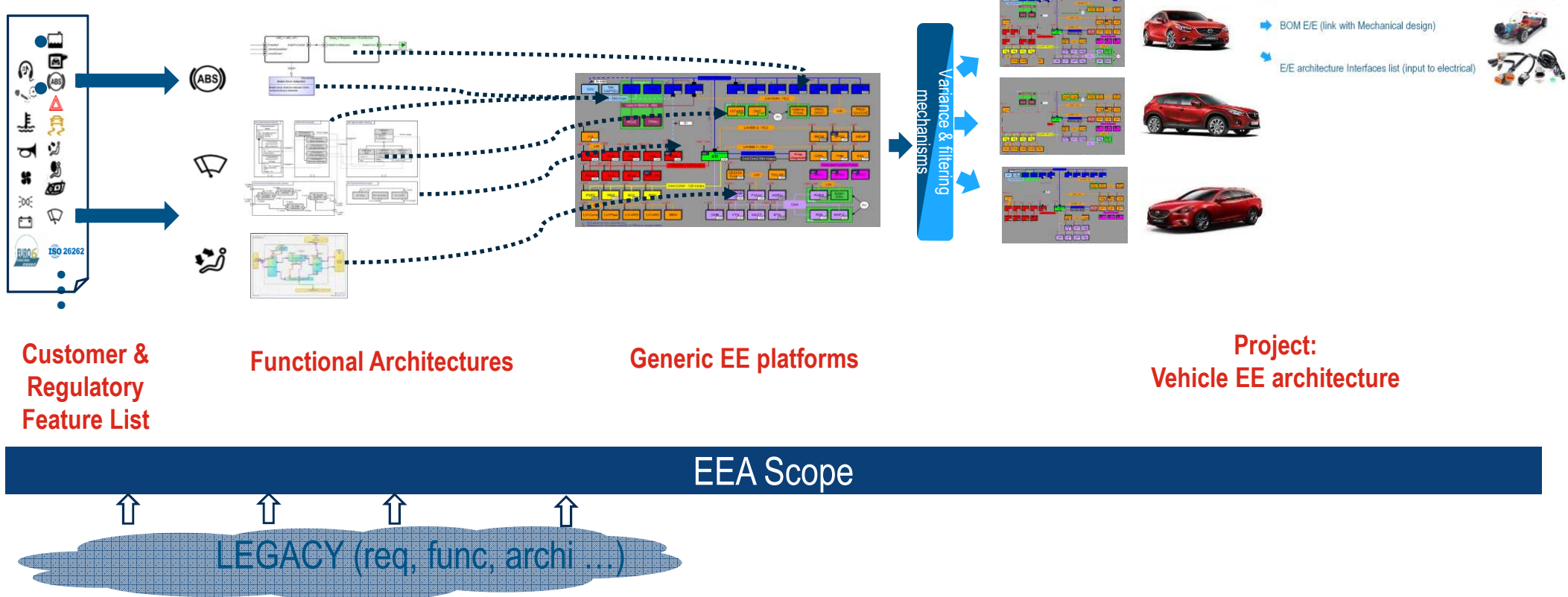



# E/E platform architecture | Involved activities

### IP capitalization & reuse

### Customer Functions

### Portfolio & Configuration

### Change Management

### Project & Dashboard

### ISO26262 Work-products

### Requirement

### Functional Architecture

### Software Architecture

### Hardware Architecture

### Communications

### Dynamic Behavior Modeling

### Simulation & Test

**E&E Architecture**

SW Components Design  
AutosarBuilder

Electrical Systems Design

Mechanical Design

Electrical Harness Design

# EE & PLM Openess required

- Dassault Systèmes Commitment to Codex of PLM Openness (CPO)

May  
02  
2012

## Dassault Systèmes Supports Industry Commitment to Codex of PLM Openness "Critical to Collaboration and Innovation"

### Dassault Systèmes Signs CPO and Continues Role as a Core Member of Codex Effort

STUTT GART, Germany and VÉLIZY-VILLACOUBLAY, France - May 2nd, 2012 - Dassault Systèmes (Euronext Paris: #12066, DSY-PA), a world leader in 3D design, 3D Digital Mock Up and Product Lifecycle Management (PLM) solutions, today announced its ongoing commitment to PLM openness by continuing to support the next phases of the Codex of PLM Openness (CPO), an initiative driven by automotive OEMs, suppliers and the ProSTEP (VIP) association.

In 2011, when industry standards association ProSTEP (VIP) and several German automotive OEMs began developing the idea of an initiative dedicated to defining and addressing problems and standards for product data management and virtual product creation, Dassault Systèmes joined them in an early phase to support the creation of the Codex of PLM Openness.

"We are very pleased that Dassault Systèmes supports the idea of the CPO and actively participated in its creation. Dassault Systèmes was one of the major contributors and lead the workgroup defining the glossary definition", says Dr. Steven Vettermann, General Manager of ProSTEP (VIP) e. V.

"For 30 years Dassault Systèmes executive team has driven PLM relentlessly towards an open, unified collaborative experience for our customers," said Dominique Florack, Senior Executive Vice President, Products, Research and Development, Dassault Systèmes. "Openness is critical to collaboration and, thus, innovation. Dassault Systèmes is very much in favor of the CPO and actively supports this effort."

Long a proponent of openness, Dassault Systèmes has architected its V8 3D Experience platform to take full advantage of its 20+ years of research and development in infrastructure protocols and interoperability. The V8 platform's Web services infrastructure is compliant with a variety of interface standards and supports multiple exchange standards, such as STEP, IGES, PTH, AUTOCAD and JT, from open interoperability between V8 and competitive PDM, CAD and enterprise systems to thousands of publicly available APIs, the V8 platform has been developed from its inception to support openness.

In an early effort at extensibility, one of the Codex's primary focal points, Dassault Systèmes created in the 1990's an open, comprehensive development environment called the CATIA Application Architecture (CAA). A resounding success resulting in hundreds of third party applications for its V8 platform, the CAA concept of extensibility was enhanced when Dassault Systèmes released its open V8 CAA2 program and made thousands of APIs available to its partner community.

"Our support of interoperability standards between V8 and other CAD, PDM, and enterprise systems has been a key focus over the past year," continued Florack. "I'm glad to see that the Codex of PLM Openness is defining what 'open' is, since the term has long been thrown about with little behind it. The irresponsible claims of openness and resolutions of non-openness have engendered unnecessary fear, uncertainty, and doubt in the industry and have adversely disaffected many customers of PLM solutions."

With the signature of this CPO, Dassault Systèmes has officially signaled to the market its willingness to continue supporting openness throughout its valued solutions.

DOWNLOAD PRESS RELEASE

**Press Contact**

Corp/France  
Arnaud Malthe  
+33 (0) 1 61 62 87 73  
arnaud.malthe@3ds.com

EMEA  
Virginia Blindenberg  
+33 (0) 1 61 62 84 21  
virginia.blindenberg@3ds.com

North America  
Elena Fernandez  
+1 (973) 442-2750  
elena.fernandez@3ds.com

Korea  
Jahyun Rhn  
+82 2 3270 7893  
jahyun.rhn@3ds.com

- Openness based on standards: data exchange, interoperability & long term archiving



# E/E PLM platform architecture | Value proposal

- **Unify E/E** data through the collaborative workflow role based access right
- Mastering cost through **re-use of E/E platform** and **variants** management
- **Predict E/E costs** and **performances** for early stage trade-offs
- **Generate high quality spec** for suppliers

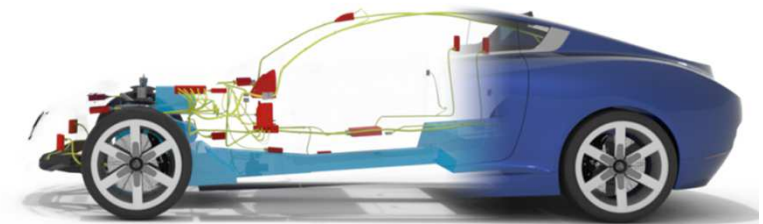

# E/E platform architecture

- **Define technical requirements** from customer features
- **Design and re-use architectures** (functional/software/hardware, communication matrix)
- **Partition functions** and software into hardware architecture
- **Create E/E vehicle architectures** from E/E platforms with variant management
- **Generate design and specification documents**
- Support trade-off thanks to **analysis capabilities**

